

Nanosat Ka-Band Communications - A Paradigm Shift in Small Satellite Data Throughput

Jan A. King
 Southern Cross Space & Communications Pty Ltd
 105 Panorama Dr. Doonan, QLD Australia 4562; ph: +61-(0)7-5471-0657
jan.king@antarcticbroadband.com

John Ness
 E.M. Solutions
 101 Hyde Road Yeronga, Brisbane, Queensland, Australia; ph: +61-(0)7-3392-7600
john.ness@emsolutions.com.au;

Grant Bonin
 UTIAS Space Flight Laboratory (SFL)
 4925 Dufferin St., Toronto, ON. Canada, M3H 5T6; +1 (416) 667-7873
gbonin@utias-sfl.net; www.utias-sfl.net

Michael Brett, Daniel Faber
 Antarctic Broadband
 P.O. Box 371, Fyshwick, ACT, Australia 2609; +61-(0)2-6239-4288
michael.brett@antarcticbroadband.com; daniel.faber@antarcticbroadband.com

ABSTRACT

Earth observation applications are rapidly being serviced using low-cost small satellites, improving economic and environmental management and creating new markets. The technology driver of this trend is a series of steady improvements in attitude control sensors and microprocessor technologies which have allowed small spacecraft to achieve arc-minute to arc-second pointing capabilities. These advancements have, in turn, enabled high performance and high resolution remote sensing instruments to be deployed on smaller and lower-cost platforms.

The constraints placed upon small satellite design for remote sensing missions have traditionally been power availability, heat dissipation and aperture requirements however as small satellite sensor technology approaches the 1 meter resolution threshold, data throughput is becoming a new and particularly challenging constraint on mission design. Ever-improving sensor resolution increases the demand on data transfer in a non-linear fashion even when corresponding improvements in data compression techniques are included. Hence, very small satellites are rapidly becoming data-bound.

Approaches to deal with this constraint to date have been based on increased memory size of the payload computer however this does not solve the problem, instead it focuses it. A more pragmatic solution to accessing the vast amounts of data harvested by small satellites in a timely manner is the development of higher speed data downlinks. If small satellites are to satisfy increasing global awareness demands, broadband telemetry links from small satellites will be required. Otherwise missions will ultimately be limited by in-orbit data backlog.

The Antarctic Broadband satellite program has developed miniaturized communications technology specifically designed to meet the data transfer requirements of such missions. Funded under the Australia Space Research Program, the project consortium, comprised of industry and research organizations, developed a number of innovative solutions to meet the challenge of transferring data from the South Pole to anywhere on Earth at very high speed. Over the past year, adaptation of this technology to the more general challenge of high-speed Nanosatellite telemetry downlinks has yielded a surprisingly versatile communication system capability. This capability can provide between 60 and 120 Mbps at 1 Watt RF output power to small Earth stations when operating from a standard Nanosatellite platform, such as SFL's Generic Nanosatellite Bus (GNB). This paper describes the system hardware and software architecture developed, the applicability of this new technology to a variety of

candidate mission types and the available frequency bands which will support a wide range of mission concepts, including deep space missions.

The outcome of applying this state-of-the-art innovation will be a paradigm shift in capability for Nanosat spacecraft and therefore the versatility and value of missions. This new functionality can be incorporated immediately on Nanosats and all larger satellite platforms, enabling new classes of missions for spacecraft of this size. Further size reductions are planned that will even extend this capability to 1U CubeSats.

WHERE ARE WE NOW? THE STATE-OF-THE-ART IN SMALL SATELLITE EARTH IMAGING

Advanced remote sensing payloads are rapidly winning the small satellite competition for the most commercially viable and profitable application. That is not all. It is becoming more certain that within the next five years small satellite remote sensing system will simply replace large satellite systems, at least in the commercial marketplace, as THE most cost effective and appropriate technology for high resolution imagery. At one point it might have been argued that the Disaster Monitoring Constellation of DMCii or Nigeriasat-2 were one-of-a-kind systems, when launched by Surrey Satellite Technology Ltd (SSTL), however, with a new contract signed between DMCii and China's 21AT for three <1.0 meter GSD resolution small satellites (350 kg) to be delivered in 2014, this game between big and small is nearly over. And, SSTL is not the only one now working on sub-meter resolution satellites. Skybox Imaging, Inc. is planning a cloud-based information system business leveraged on data obtained from their own satellite constellation using ≈ 1 meter resolution small satellites. [1] So, where are we right now with small satellite remote sensing? What is in orbit and working? Figure 1 is SSTL's Nigeriasat-2 in preparation for launch.

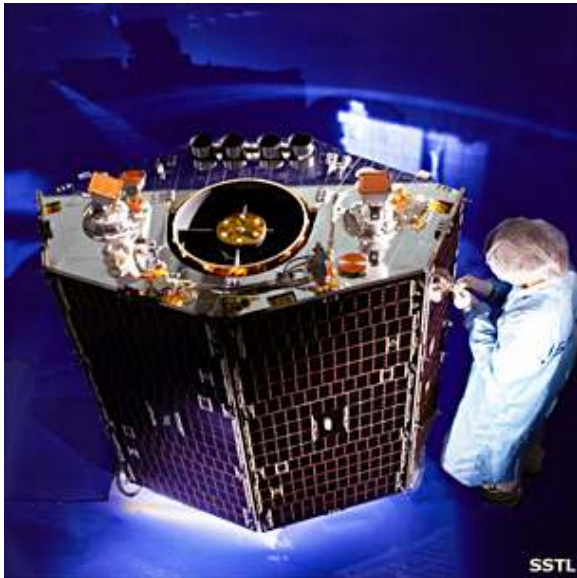

Figure 1. Nigeriasat-2

The spacecraft was successfully launched on August 17, 2011 into a 700 km sun-synchronous orbit, with a 22:30 LTAN. An initial image, using Salt Lake City Airport as a "reference grid" was released publicly on 28 September 2011 (Figure 2).



Figure 2. First Released VHRI Image from Nigeriasat-2

This image is available everywhere on the web (courtesy SSTL, NASRDA and BBC) and the resolution is quite easily verifiable using airport infrastructure as a reference. The primary imager resolution is 2.5 m GSD and is panchromatic. The spacecraft mass is approximately 300 kg. The spacecraft is capable of down-linking up to 400 images per day (and uses a 2 day repeat ground cycle). The images are downloaded using an X-band high speed link (using the frequency band 8.025-8.400 GHz). In order to achieve the program requirement to download to a single ground station 100 VHRI (very high resolution images) a day demands a data rate of 40 Mbps for the link. There is also a 32 m resolution swath-width MRI (medium resolution image) instrument on-board. This imager is multi-spectral and has 4 color bands. The MRI instrument requires another 40 Mbps downlink data rate to deliver the same 100 images. The analysis of these data rates are addressed in another important SSTL paper. [2] The important notion here is to associate an 80 Mbps downlink requirement with the combined Nigeriasat-2 payload. Further, each image set, which produces a "scene," contains 1.3 Gbits and it can be stored in 0.13 GBytes of memory. Thus, in order to store one day's data requires 13 GBytes of memory.

This is where we are now. Fundamentally: 300 kg spacecraft mass → 2.5 m GSD resolution → 80 Mbps data rate → 15 GBytes of data storage → 2012. But, the world has not remained static since September 2011 and the next generation system is already in production and it will be capable of < 1.0 m GSD resolution. SSTL will deliver three such satellites to *2IAT* in 2014. See Figure 3. Assuming the same pixel definition of 10 bits and the same scene size of 20 km X 20 km; and again, assuming a requirement of 100 images per day delivered under the same conditions, the data rate scales as the square of the resolution so the new 1.0 m resolution VHIR instrument would require a platform supporting data rate of approximately 250 Mbps. If the same spacecraft also carries a MRI instrument it would be necessary to concatenate yet another 40 Mbps into the data stream. Hence, the combined data rate will then be pushing 300 Mbps if the data were to be delivered to only a single ground station. In order to store the 100 images would require a data memory of approximately 80+ GBytes. The pattern that emerges from this simplified analysis is that small satellite missions are rapidly becoming data bound more quickly than they are becoming resolution limited.



Figure 3. SSTL 300-S1 With Sub-Meter Imager

But, we are still not done yet. Now, very near on the small satellite horizon comes the next form of remote sensing instrument – the Synthetic Aperture Radar (SAR). SSTL teaming with SAR experts at Astrium UK are developing a low cost S-Band SAR spacecraft which can be used for a large number of applications. Surrey will use a very similar platform for their first SAR mission (Figure 4). That a small satellite can host a medium resolution SAR instrument is impressive, however, such missions are known to be very data intensive. A single two minute scan (which can vary in swath width from 15 km to 750 km) can produce up to 30 GBytes of data which requires a downlink data rate (planned for X-Band) of 105 Mbps. So, one can see



Figure 4. SSTL's Planned S-Band SAR Platform

where this is headed. And, once again, SSTL/Astrium are not the only company participating in this field. [3] The message here is that ever more sophisticated small satellite instruments can be expected to produce a correspondingly larger data stream and the spacecraft data system must keep up. More storage doesn't help. It only focuses the problem. For such missions data will rapidly accumulate in memory and must be downloaded promptly. Storing data necessarily increases the time required to download the sensor's vital information, once an Earth station is in-view. The only mitigation to increased data rate is an increase in the number of mutually exclusive (i.e., non-overlapping) ground stations. As time goes on and instruments get smaller (subject, of course, to the constraints of diffraction limited resolution), platforms too will get smaller but, data rates will remain high.

THE DISPARITY BETWEEN PLATFORM SIZE AND SYSTEM DATA RATE

Perhaps an example of an alternative reality will bring the demand for platform data rate into clearer focus. Presenting a paper relevant to the subject topic at this conference in 2008, Pumpkin, Inc. developed a concept for an 8 meter GSD imaging platform. [4] Called MISC (Miniature Imaging Spacecraft), the platform proposed is a 3U Cubesat, which is technically a Nanosat. Figure 5 shows the selected configuration. Cubesat designs have hard limits on exterior dimensions as these platforms are constrained inside a

“pod” at launch. In the paper Pumpkin carefully matched the Rayleigh criterion resolving power to available lens systems and the CCD array selected. They propose to use commercial 35 mm DSLR lens

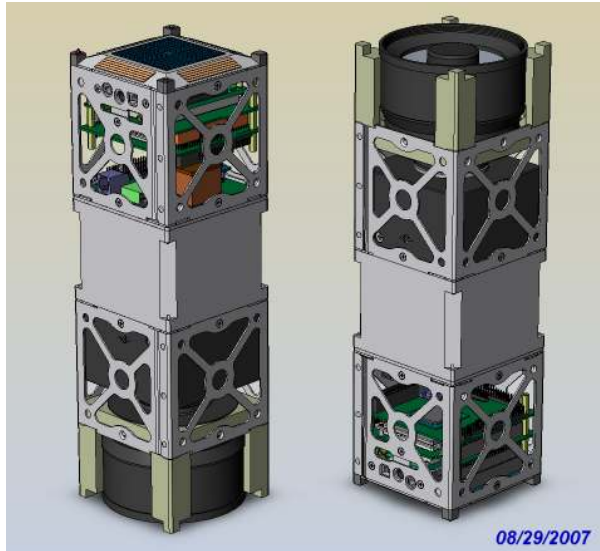

Figure 5. MISC Configuration (Courtesy Pumpkin, Inc.)

system components to develop a proof-of-concept payload. A summary of the system characteristics after the trades have been completed is shown in Table 1.

Even this very small MRI system is clearly downlink data limited. While Pumpkin talks about using VHF/UHF links for low cost ground stations, the reality is that a commercial license to use such low frequency spectrum in the Earth Exploration Satellite Service is unlikely to be granted by the FCC or other frequency regulatory administrations. Even at S-Band, spectrum in this service does not exist for commercial purposes in the U.S. (although there is some possibility of using the 2200 – 2290 MHz band in other countries for this purpose). However, spectrum issues aside, let’s continue this analysis but, use a set of ground rules similar to those being used for Nigeriasat-2: 10 bits per pixel, 1 ground station, 36 minutes of pass time per day for a near-Equatorial ground station and a requirement to downlink 100 *scenes* per day. This also allows us to make direct comparisons. Like the Nigeriasat-2 case we assume a margin for extra files and data loss of 33% (or an efficiency of transmission of 75%). At UHF the highest data rate envisioned by Pumpkin for MISC was 57,600 bps. With the required margin, the amount of data to be transmitted (apportioned to each scene) is 212.6 Mbits for the MISC instrument. To transmit that scene requires just under 3700 seconds or just over one hour. So, not even one of the 100 required images can be downloaded per day at this data rate using UHF

spectrum. A reasonable data rate to assume at S-Band for such a system would be 5 Mbps but, the spectrum associated with this data rate would be very hard to obtain, from a regulatory perspective. However, even at 5 Mbps, one image would require 42 seconds to

Table 1. MISC Mission/Payload Overview

Characteristic:	Value:
Focal Length:	600 mm
Aperture:	75 mm (f/8)
Rayleigh Limit ($\lambda = 510$ nm):	8.3 μ m
Hyperfocal Distance (CoC = 15 μ m):	3,000 m
Image Size:	16 MP
Spectral Response (λ):	380-700 nm
Imager Dimensions:	36.1mm x 24.0 mm
Active Pixels:	4872 x 3248
Pixel Size:	7.4 μ m x 7.4 μ m
Orbit Altitude:	540 km
Ground Square per Sensor Pixel:	6.7 m
Ground Scene Dimensions:	32.5 km x 21.5 km
Ground Area per Image:	702 km ²
GSD (Diffraction Limited):	7.5 m
Maximum Exposure Time:	500 μ s
Capture Speed:	16 MP/s
Approximate Image Size:	160,000,000 bits

download, and 100 images would require 71 minutes of access time at the ground station. Thus, even a 5 Mbps link for MISC will not satisfy the same 100 image requirement being met by the Nigeriasat-2 MRI

payload component. This discussion ignores the issue of RF power required to close the link and energy availability on-board to support that RF transmission. It is assumed that these problems can and will be resolved. Also not discussed, is the ability for an existing range of very small platforms (Cubesat to Minisat) to support the pointing requirements of small but capable optical payloads, however, that capability has been reviewed elsewhere. High accuracy, 3-axis stabilized AOCs systems for very small satellites now exist. [5]

FACTORS LIMITING THROUGHPUT

Therefore, what has been demonstrated so far is simply that even very modest platforms are now capable of supporting medium to high resolution remote sensing instruments but, as the platform and instrument sizes come down along with the price, the limiting factor for very small spacecraft becomes data throughput. Throughput is limited by data rate and satellite access time per day from a set of independent ground stations (for each LEO satellite). We also restate that storing the data on-board beyond the need to buffer it for ground station accessibility works against the system design. It only makes matters worse and “focuses” or increases the data density requirements at all of the ground stations. Any delay in data delivery beyond the first opportunity to download it makes matters worse – in the most general sense of the data delivery problem.

There are very few options with very small spacecraft to increase data rate. Lossless data compression is the first to come-to-mind. We assume here that this will be done and that the data processing power (and DC power) to manipulate the data is available. For Earth image data, this will, most likely amount to a factor of from 2 to 10 advantage. And, this factor, while very helpful, does not alter the basic conclusions drawn here. It is safe to say that the rest of our options lie within the link budget of the downlink communications system of the platform. That is, the link supporting the remote sensing instrument(s). Starting with the basics, there is a clear, unambiguous set of statement that can be made about a simple communications link. The proof of these statements (in this instance) is an exercise left to the student. [This can be achieved empirically or analytically as you like]. The facts are:

1) If a communications link uses a transmitter and a receiver where both sides of the link (transmitter and receiver) use omni-directional antennas then the supported data rate (all other link parameters remaining constant) decreases with increasing frequency of transmission.

2) If a communications link uses a transmitter with an omni-directional antenna and a receiver with a directional (high gain) antenna with a fixed aperture size, the performance of the link is independent of the frequency of the transmission. This also works the same if the transmitter has the high gain antenna and the receiver has the omni antenna.

3) If a communications link uses a transmitter and a receiver with directional (high gain) antennas both with fixed aperture size, the supported data rate of the link (all other link parameters remaining constant) increases with increasing frequency of the transmission.

“Fixed aperture” means an antenna like a parabolic reflector (dish) or a horn antenna is used. It remains constant in size as the frequency is varied. Such antennas have the property that their gain increases as the square of the frequency of operation, provided that they are fed properly.

There are many qualifications, however, this general trend is the most important factor to be noted and it can be concluded that spacecraft systems requiring higher throughput will benefit most from the use of high gain antennas and the highest practical transmission frequency.

One may also increase either the number of ground stations or the throughput problem may also be resolved by increasing the gain of the ground station receiving systems, while reducing their noise temperature (in effect, improve their G/T). Increasing the number of ground stations has an easily calculable cost and for commercial systems it can be very high, once operational manpower is considered.

Finally and significantly, the link can be improved by decreasing the *required* signal-to-noise ratio (S/N) or in contemporary terms the E_b/N_o . That can be done by adjusting both the modulation (MOD) and coding (COD) used [taken together we have a new acronym, MODCOD] to best fit the bandwidth and link conditions of the system.

Nothing else significant can be done to improve the throughput of the system. These are really the only options for a LEO system.

THE EFFECT OF HIGHER FREQUENCIES AND BETTER MODCOD ON VERY SMALL SATELLITE THROUGHPUT

If all these things that could be done to the system link performance are done, and at the same time – what would be the result? Let us go back to the Pumpkin MISC example. Given the same spacecraft, fitted with

a UHF canted turnstile antenna on the end opposite the imaging aperture, its throughput performance is now calculated. Let's assume a 45° angle of cantation for the antenna elements (which would be typical for many Cubesats). It is also assumed for this example that a standard PSK transmitter is used with a 1 watt RF output (which will cost at least 2.5 watts of DC power when it is operated). No coding is assumed. Further, to optimize the data rate, everything that can afford to be done on the ground, will be done. It is assumed that a 7 meter parabolic reflector antenna is employed at the ground station. Such an antenna would be 10λ (10 wavelengths) in size which is the minimum recommended for proper feed designs. A mini-link budget shows the results for this case (Table 2).

Table 2. MISC UHF 1 Mbps Link Budget

Parameter:	Value:	Unit:
S/C Transmitter Power Output:	30.0	dBm
Transmitter Losses:	-1	dBm
S/C Antenna Gain	1.5	dBIC
S/C EIRP:	30.5	dBm
Path Loss (435 MHz; 2180 km; 5° elev. angle):	-152.1	dB
Polarization Loss:	-1.5	dB
Other Misc. Losses (Pointing; Atmosphere):	-3.0	dB
Isotropic Signal Level at Ground Station:	-126.1	dBm
Ground Stn. Antenna Gain (7.0 m; 55% A.E.)	27.5	dBIC
Ground Stn. Effective Noise Temperature:	400	K
Ground Stn. G/T:	1.5	dB/K
Ground Stn. C/No:	74.0	dBHz
Ground Stn. Eb/No (for 1.0 Mbps):	14.0	dB
Required Eb/No (PSK; 10E-6 BER; 1dB I.L.):	11.7	dB
Link Margin:	2.3	dB

Once again, a 540 km altitude orbit has been assumed. It is noted that the link will support a 1 Mbps data rate but, not with a *commercial* link margin (+6dB). However, there is no possibility of obtaining a frequency assignment for that sort of bandwidth at such a low frequency anyway. A 1.0 Mbps link would still fall short of delivering 100 scenes per day via a single ground station of this sort, and by a significant margin. The ground station would be expensive and the dish pedestal would require a significant civil works project.

Now, the same volume can be used “inside” the canted turnstile to house a very miniature dish antenna and Az-El mechanism to point it. The dish size is 100 mm (for simplicity it is estimated that the antenna extends the spacecraft length by ≈1U). This antenna diameter approximately satisfies the 10λ rule, so it is viable. It is noted that the spacecraft is now 4U in length and doesn't fit into the P-pod any longer. This paper is not an exercise in mechanical engineering; it is an investigation to evaluate the minimum volume needed to house a remote sensing system where the data throughput matches the instrument requirements. Hence, the new mechanical envelope for the Pod for such a 4U system can be discussed at a future time. It is

not an important consideration here. In the case of our example, the antenna system for the high speed downlink is approximately the same volume as the lens assembly of the instrument.

The assumption is made that proper Earth Exploration Satellite Service spectrum is used for the mission in Ka-Band - at a “space-to-Earth” frequency of 26.25 GHz (see Table 5 below). Further, a high degree of modulation and coding for this example is employed to show the effect it has on the link. To be fair, one must also include in a link budget at these frequencies a larger negative factor for water vapor losses that occur as the signal passes through the lower atmosphere. The dish size at the ground station is then reduced from 7.0 meters to 2.5 meters. This represents a significant cost savings. The link budget now looks like this (Table 3).

Table 3. MISC Ka-Band Link Budget

(Using EESS Spectrum)

Parameter:	Value:	Unit:
S/C Transmitter Power Output:	30.0	dBm
Transmitter Losses:	-1	dBm
S/C Antenna Gain (10 cm dish; 55% A.E.; 25.3 GHz):	26.2	dBIC
S/C EIRP:	55.2	dBm
Path Loss (26.25 GHz; 2180 km; 5° el.ang.):	-187.6	dB
Polarization Loss:	-0.5	dB
Other Misc. Losses (Pointing; Atmosphere):	-9.5	dB
Isotropic Signal Level at Ground Station:	-142.4	dBm
Ground Stn. Antenna Gain (2.5 m; 55% A.E.)	54.1	dBIC
Ground Stn. Effective Noise Temperature:	245	K
Ground Stn. G/T:	30.2	dB/K
Ground Stn. C/No:	86.4	dBHz
Ground Stn. Eb/No (with MOD=8PSK; COD=5/6)	4.6	dB
Channel Bandwidth:	50	MHz
Spectral Efficiency Achieved:	2.48	bits/Hz
Achieved Data Rate:	103.3	Mbps
Link Margin:	0.8	dB

This link has been achieved while accounting for all proper losses except rain and heavy clouds. This kind of link is known as a *clear sky* link. The resultant two order-of-magnitude average improvement in link performance takes this mission example from a losing proposition, from a commercial perspective, to a viable candidate. At a 100 Mbps data rate the 100 images per day from MISC can be downloaded in 3.6 minutes. This is 1/10th of the available visibility time from a single ground station located near the Equator. In fact, it is such a short duration that transmitter efficiency (normally vastly important to a Cubesat) hardly matters. Efficiencies of from 7 to 10% (DC/RF) for the transmitter would still fit within a Nanosat energy budget. One might even choose to turn off the imager during the download period and invert the platform so that the Ka-Band antenna is generally Earth-looking. This would simplify the spacecraft design and this is even more feasible with the short download time now required. The pointing mechanism could quite easily be

eliminated and then use the spacecraft itself to direct a fixed mounted antenna toward the ground station during download times. The -3 dB beamwidth of a 100 mm dish at these frequencies is 8°, so this would be a modest attitude control task. There is another factor easily missed here. A frequency assignment of only 50 MHz is used in order to support a 103 Mbps data rate. The spectral efficiency for the particular MODCOD selected is 2.478 bits/Hz. Such a high spectral efficiency is one of the big advantages of using modern modulation and coding standards. This will be discussed in greater detail below. With the addition of a Ka-Band link the Pumpkin MISC mission – a 3U Cubesat with its initial 35 mm DSLR camera technology has been made into a powerful tool – a Nanosat not to be taken lightly.

With Pumpkin, Inc. having completed all of the front end work back in 2008, it is hoped that the initial point has been made clear. For the price of a high quality 35 mm camera/CCD system and a ≈1U Ka-Band communications system, it is possible to put even a Cubesat into the “serious contender” remote sensing mission class. And, as has been demonstrated, with that spacecraft size data rates in excess of 100 Mbps can be delivered to a small (if not totally low cost) ground station. Note that, volume-wise, a 2.5 meter dish is no larger than that required by 4 UHF yagi antennas (mounted 2 over 2) used by many universities (and many amateur radio stations) for their standard Cubesat or Nanosat ground stations. From a mission perspective, it is now left to the reader: What else can be done with 100 Mbps and a Nanosat platform?

The remainder of this paper addresses the “buts” and “excepts” that you will now currently have in your mind as you’ve been reading along.

A FUNNY THING HAPPENED ON THE WAY TO THE SOUTH POLE

Those readers who have followed the progress of this paper’s authors will be aware that they represent a group known collectively as Antarctic Broadband. This team has recently completed a study focused on the provision of high speed satellite communications services to/from the Antarctic Bases using a low cost satellite approach. The study was funded by a grant provided by the Australian Department of Innovation, Industry, Science and Research. Under that program, a comprehensive trade study leading to the down-selection of an Operational System Candidate was carried out. In order to verify the performance of a Ka-Band system in a non-GEO orbit, to verify the link behavior at Ka-Band under Antarctic conditions and to verify our advanced modem performance, a LEO

demonstration mission design was carried out. This was done to the CDR level of detail. In support of that effort a fit/form/function transponder system, designed to the demonstration mission requirements was developed and functionally tested. Additionally, a protoflight Nanosat platform was fabricated by UTIAS/ Space Flight Laboratory (the platform was SFL’s GNB or Generic Nanosat Bus) and delivered to Australia where it was integrated with the prototype transponder and the spacecraft was then tested as a *flat-sat*. The integration milestone was achieved on schedule and within budget. Hence, this was not simply a paperwork exercise. The linear transponder produced under the Antarctic Study contract had the following general characteristics (see Table 4).

Table 4. Ka-Band Developmental System

Linear Transponder Characteristics	
Property	Performance
Mass	1739 grams
Forward (FWD) Link	>100dB Gain >28dBm Output Power Bandwidth: 16 MHz
Return (RET) Link	>100dB Gain >10dBm Output Power Bandwidth: 500 kHz
Receive Frequency	29.975 GHz
Transmit Frequency	19.725 GHz
Frequency Drift (FWD)	<10 kHz from startup; <1kHz after 15 sec
Frequency Drift (RET)	<11 kHz from startup; <1kHz after 15 sec
Beacon Level FWD	18 dBm (~P1dB-10)
Beacon Level RET	3 dBm (~P1dB-7)
DC Input Power	<10 Watts
Intermodulation level	-20 dBc (Forward Link)

Photos of some of the hardware; fully fit/form and function to CDR requirements are shown in Figure 6.



Figure 6a. Antarctic Broadband Ka-Band Prototype Transponder (Central Tray)

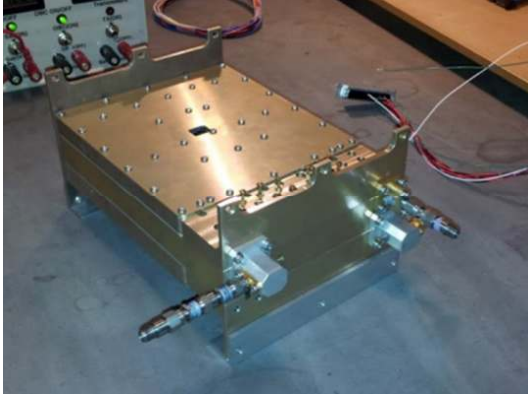

Figure 6b. Completed Ka-Band Transponder Prototype

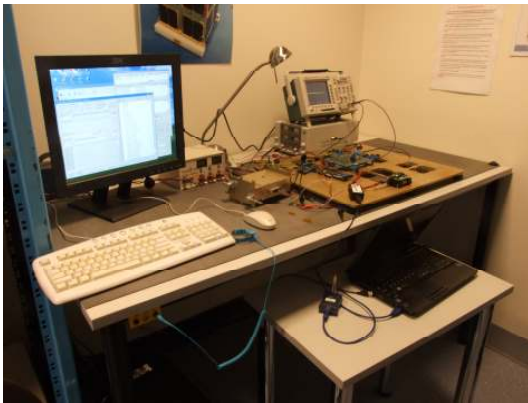

Figure 6c. Transponder and Flat-sat under Test

The *transponder payload* is actually a dual transponder, with the FORWARD link and the RETURN link transponders contained within one envelope. For Internet communications full duplex operation is essential so, the transponder was configured to operate with wideband performance in the FORWARD direction while providing a more narrowband communications path in the RETURN direction. In the case of the demonstration system the return path will serve primarily to provide acknowledgement of receipt of packets sent in the FORWARD direction. The overall block diagram of the hardware is given in Figure 7. It should be noted that this system has a total of four high gain antennas. Two for each link pair. Of these antennas, two are fixed to the platform while two are co-aligned and moved via a common single axis positioner. This is organized so that the FORWARD uplink antenna is paired with the RETURN downlink antenna and vice-versa.

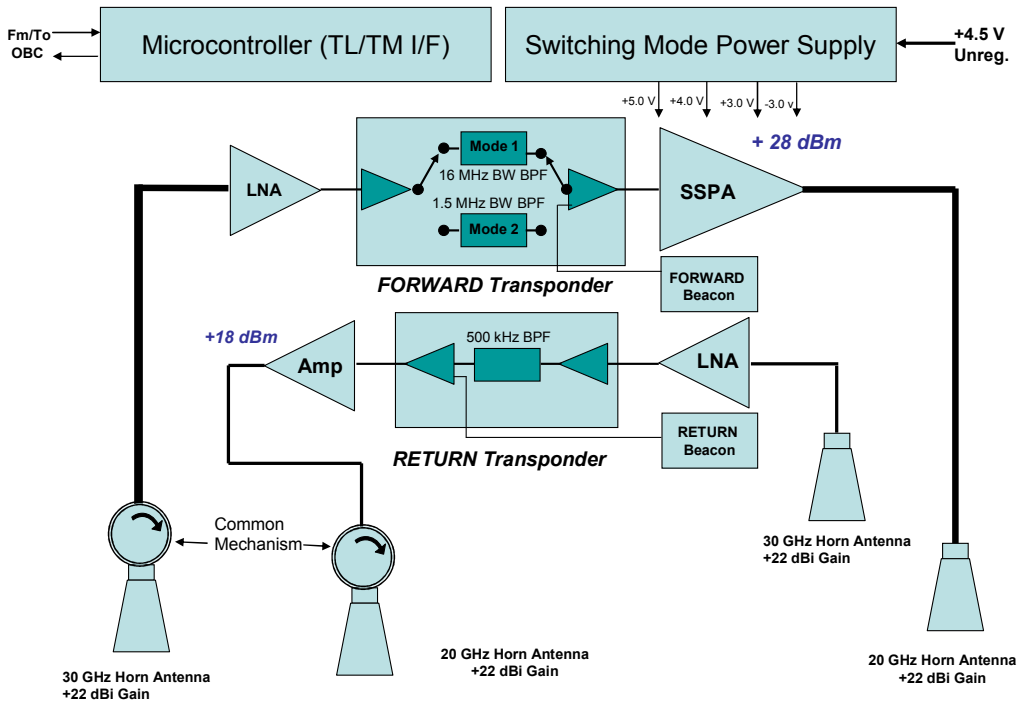

Figure 7. Ka-Band Prototype Transponder Block Diagram

This organizational arrangement serves a very specific purpose in the case of the Antarctic Broadband demonstration mission. In this instance, a LEO communications satellite is in mutual contact with two ground stations desiring to communicate with one another. Clearly, both must have mutual visibility of the spacecraft. High gain antennas are used all the way around (i.e., for all links TX and RX). For this to work the spacecraft AOCS is very busy. Using two degrees of freedom (called here Roll and Pitch) the satellite points the two antennas fixed to the bus toward Communications Station #1. The platform itself has one degree of freedom remaining (Yaw). The spacecraft Yaw direction (which is a pure rotation about the fixed antenna axis) is then commanded along with the single axis positioner holding the two remaining antennas to direct the two co-aligned horns in the direction of Communications Station #2. The attitude of all 3 spacecraft axes and the antenna positioner must be updated continuously as the spacecraft moves in orbit relative to the two communicating ground stations. For two stations located at typical bases in Antarctica, from a 1000 km circular SSO, pointing angle rates of change can be as high as 5 degrees/second for short periods but, are rarely above 2 degrees/sec. The GNB platform, configured to contain the transponder and the four antennas and single axis positioner, is depicted in Figure 8. It should be noted that the dimensions of the cubical spacecraft are 200 mm per side.

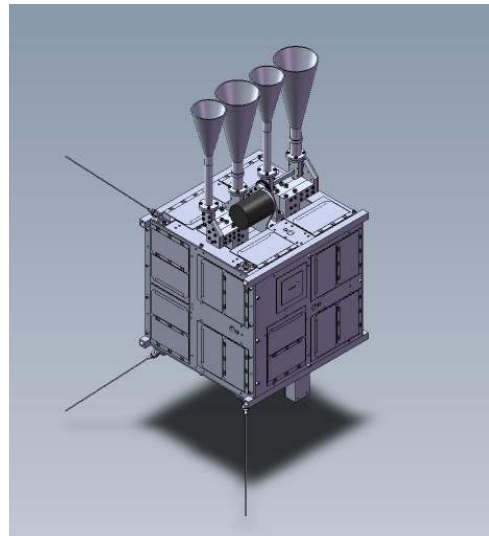
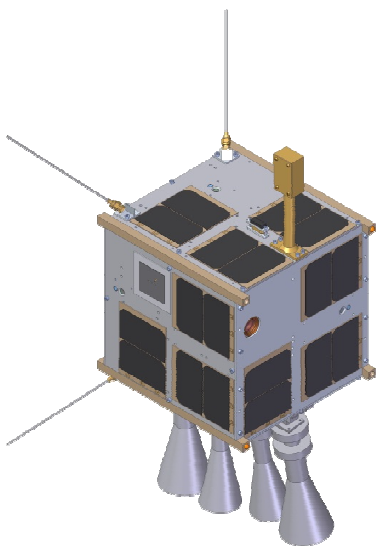

Figure 8a, 8b. Two Views of GNB with Ka-Band Transponder

The flight computer computing all of the angles involved must keep track of its own *position* relative to the Earth in an Earth-rotating coordinate system and then keep track of two vectors directed toward two fixed *positions* on the Earth in a spacecraft body-oriented coordinate system – while the AOCS system maintains knowledge of its own *attitude* relative to the Earth based on its sensor data. The update rate of all angles must not be slower than about once per second in LEO orbit. All of this is essential for a LEO system to provide two-way high speed communications between two positions on Earth when all stations are using highly directive antennas.

An Alternative Application

Hence, we have solved the problems necessary for a Nanosatellite carrying a Ka-Band transponder to point at two different targets on the Earth simultaneously. Note the spacecraft can continue to point toward both of them simultaneously... while it moves. Having solved this specific problem for the Antarctic application it recently occurred to us that we have solved a far more general and useful problem. In short: what if one pair of antennas was replaced with an optical instrument—a staring payload? (Or alternatively, a push-broom instrument whose detector has a scan mirror in front of a fixed detector, providing a cross-scan motion.) In effect, the two fixed antennas are exchanged for a remote sensing instrument with a baffle. The other two antennas remain on an articulating positioner (one or two axis motion may be required depending on the remote sensing payload characteristics). The two antennas now become the high speed downlink and



uplink channels from and to the instrument. For the application in mind here, the RETURN link transponder may be eliminated (unless it serves some other useful purpose). The FORWARD link transponder is then broken into two separate components: a telemetry transmitter and a command receiver. The command receiver thus obtained by breaking up the transponder is, perhaps a “nice-to-have” item but, could be very effective in some applications. It would make use of the smaller horn antenna on the articulated platform. But, what is really needed is the transmitter derived from the Ka-band FORWARD downlink elements. The transmitter, thus derived is shown in Figure 9. A phase

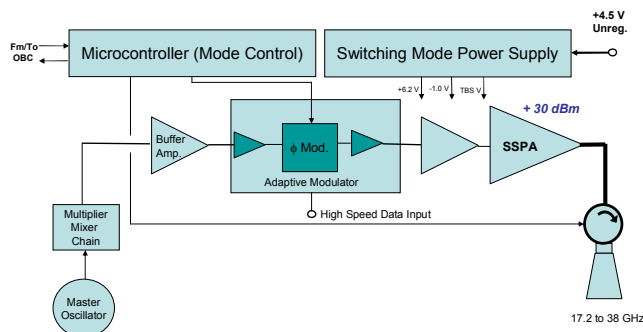

Figure 9. High Speed Ka-Band TLM TX Based on Original Ka-Band Transponder

modulator has been added in front of the final amplification stages and the degree of phase modulation is adjusted by the microcontroller used for other purposes in the transponder design. The

master oscillator and multiplier chain must be modified to produce a single carrier frequency of the correct value. The center frequency of the transmitter will likely remain constant for any one mission design, however, there are several applications for such a transmitter within the Ka-Band. So, the oscillator/multiplier/synthesizer design must be able to select an output frequency over a wider range than before.

The Earth Exploration Satellite Service has frequency allocations in several bands throughout what is generally characterized as *Ka-Band*. The use of such a transmitter, as will be seen, even opens up the opportunity for small satellites to go to Venus or Mars thus, the “deep space” frequency band at Ka-Band is applicable. Table 5 is a summary of the ITU table of allocations for the applicable services and demonstrates that the transmitter design should be capable of operating over the frequency range from 18.1 to 35.2 GHz. The table is also applicable to the command receiver design discussed in this paper as well, since about half of the frequencies listed are uplink only (Earth-to-space). As can be seen the transmitter needs to be designed to operate over about one octave (factor of 2) in frequency. Hence the synthesizer/multiplier chain and particularly the SSPA in the overall amplification chain must have relatively broadband performance characteristics. The target output power of the transmitter has always been 1.0 watt (30 dBm) at an efficiency goal of 10% minimum. While this is far from a highly efficient design, it is what can be expected from current pHEMPT technology using 0.25 μm 3MI processing.

Table 5. Summary of ITU Frequency Bands for EESS, FSS SRS, SRS (Deep Space), and Inter-satellite Services

Allocation to Service(s):	Frequency Band:	ITU Regions Applicable:	Allocation Status:	U.S. Table: Use Allowed?		Link Direction:	Comments:
				Gov.	Non-Gov.		
SRS (deep space)	16.6 to 17.1 GHz	1,2,3 (All)	Secondary	YES	NO	Earth-to-space	Appears to be a very weak allocation
FSS	17.3 to 18.1 GHz	1,2,3 (All)	Primary	NO	YES	Earth-to-space	NGSO/FSS May be of interest.
FSS	18.1 to 21.2 GHz	1,2,3 (All)	Primary	YES	YES	space-to-Earth	NGSO/FSS May be of interest.
Intersatellite Service	24.45 to 24.65 GHz	1,2,3 (All)	Primary	YES	YES	space-to-space	Could be useful for many applications
Intersatellite Service	25.25 to 25.50 GHz	1,2,3 (All)	Primary	YES	YES	space-to-space	Secondary Status for Non-Gov. Users In U.S.
EESS/SRS	25.5 to 27.0 GHz	1,2,3 (All)	Primary	YES	NO	space-to-Earth	Useful Outside U.S. Only for Non-Gov. Users
EESS	28.5 to 29.1 GHz	1,2,3 (All)	Secondary	NO	NO	Earth-to-space	Useful Outside U.S. Only in All ITU Regions
EESS	29.5 to 29.9 GHz	1,2,3 (All)	Secondary	NO	NO	Earth-to-space	Useful Outside U.S. Only in All ITU Regions
SRS (deep space)	31.8 to 32.3 GHz	1,2,3 (All)	Primary	YES	YES	space-to-Earth	Primary Ka-Band DSN Downlink; Careful Coordination
Intersatellite Service	32.3 to 33.3 GHz	1,2,3 (All)	Primary	YES	YES	space-to-space	NGSO use is secondary to GSO use
SRS (deep space)	34.2 to 34.7 GHz	1,2,3 (All)	Primary	YES	YES**	Earth-to-space	** Must be used by Non-Gov. U.S. at Goldstone Only
SRS	34.7 to 35.2 GHz	1,2,3 (All)	Secondary	NO	NO	Both Directions (?)	Useful Outside U.S. Only

Key:
FSS = Fixed Satellite Service
EESS = Earth Exploration Satellite Service
SRS = Space Research Service
Intersatellite Service = Space-to-Space Links Only

This, of course, means the transmitter thermal design is more critical and conduction paths to exterior radiators must be carefully considered. In this instance we can build upon what we know from the design work already completed for the Antarctic Broadband demonstration transponder. This unit was developed as the primary instrument for the GNB Nanosat developed by UTIAS/SFL. [6] This platform now has flight heritage and the thermal platform design has been verified in flight. Our thermal design and power design validates that we can support at least a 30 minute ON time of the transponder under all orbit conditions (HOT and COLD cases). This has also been verified by limited laboratory testing. It is certain that the new transmitter design will be lighter mass and much smaller than the transponder as it represents only about one quarter of the volume of the transponder. So, the conduction modeling will have to be redone. The new enclosure will be much smaller, however, the primary heat source will also be closer to the ultimate radiating exterior panels. In any case, we are confident that, even using a 200 mm cubical Nanosatellite we can sustain 9 to 10 watts of dissipation for at least 30 minutes, which is well more than the duration of an overhead satellite pass in a 500 to 700 km orbit (ideal for remote sensing).

While it is not possible to completely reuse the transponder as a transmitter, large portions of the design remain the same, thus reducing risk and development time. In particular, the oscillator, the multiplier/synthesizer components and the high power amplifier chain of the FORWARD transponder will be reused.

Significant Improvements: Adaptive MODCOD

There is one element of the transmitter design which will be modified or perhaps one should say “placed in space” as opposed to being left on the ground as we plan for Antarctic Broadband. This is an adaptive MODCOD modulator. There are prices to be paid for using millimeter wave (mmW) spectrum. One which has been already noted is the poorer DC to RF efficiency of the amplifier chain used in the transmitter at such high frequencies. But, one must also deal with some elements of quantum physics that do not work in favor of data transmission in the mmW region. In the atmosphere, molecular absorption occurs at selective “spot” frequencies. In particular, water molecules suspended in the atmosphere attenuate radio signals by exciting H₂O molecular bonds. Specifically, the O-H bond rotation selectively absorbs RF energy from a passing signal. The rotation is a quantum effect and appears as a

sharp absorptive resonance. However, it is “pressure broadened” in frequency by all atmospheric gases. There is one particular water absorption band within the Ka-Band that peaks near 22 GHz.

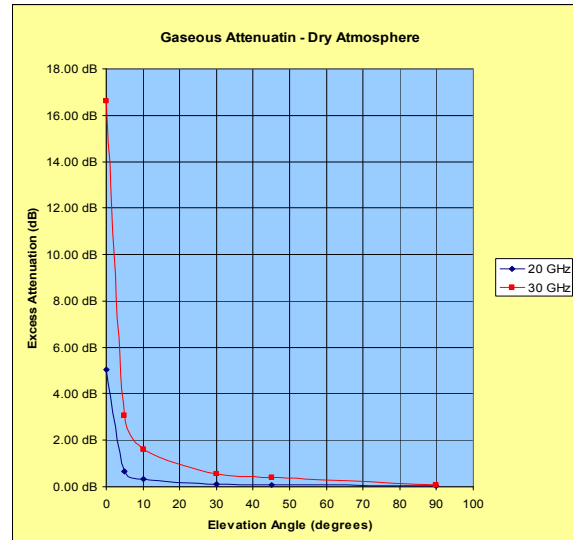

Figure 10. Dry Atmosphere ($T_o=20^{\circ}\text{C}$; $\rho_o = 0.001 \text{ g/m}^3$)

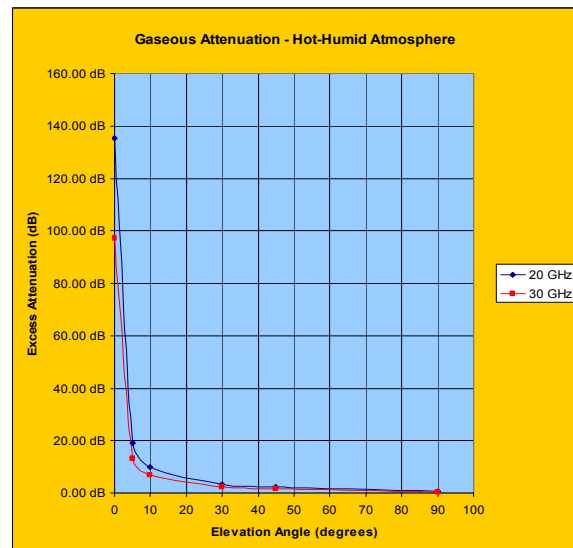

Figure 11. Hot Humid Atmosphere

($T_o = 30^{\circ}\text{C}$; $\rho_o = 18 \text{ g/m}^3$)

It has a moderate impact on satellite links and for a moderately dry atmosphere the atmosphere absorbs about 1 dB of satellite signal at that frequency, even if the signal source is at zenith (elevation $\angle = 90^{\circ}$). But, the absorption at all elevation angles depends upon atmospheric pressure and relative humidity. Figure 10 gives the attenuation due to water at all elevation angles for a dry atmosphere while Figure

11 presents the excess attenuation for a hot, humid atmosphere. In this environment, the link result varies as a function of many meteorological factors. The elevation angle is continuously changing due to the LEO orbit; the relative humidity (and hence ρ_0) varies statistically as does the temperature. As might be suspected, the downlink satellite signal is even more affected by rain and dense cloud conditions than water vapor. Thus, the entire link must be treated statistically. Typically, a cumulative distribution function is used to model the link where the probability of the link being attenuated by more than X dB (excess attenuation) is plotted as a function of link availability, expressed as a percentage. Things are more complex yet, since rain and clouds also generate a noise contribution at Ka-Band. Hence, water in the atmosphere has a net adverse effect on the system "S" and "N." In effect, at Ka-Band, water impacts both the numerator and the denominator of the S/N of the link result. Extensive work has been carried out to develop rain models for determining link margin requirements as a function of ground station location. [7,8] Antarctic Broadband makes extensive use of the ITU P618-Rev 6 rain model in developing our system performance estimates. The effects of rain at mmW frequencies can be devastating to link performance and carrying very large link margins at all times as a means of dealing with infrequent rain events is very costly and would likely be a business deal killer were it not for other means that have been developed to cope with this difficult problem. Infrequently, rain can increase the excess path loss by more than 20 dB at many locations. Such link margins are unaffordable.

Fortunately, the solution to this problem is now well in hand. In order to make use of these frequency bands for commercial purposes the satellite broadcast (BSS) and fixed satellite (FSS) industries have developed adaptive modulation and coding (MODCOD) modem technology. In the event that

two-way paths exist between any two locations connected by satellite (FORWARD & RETURN), it is possible for each receiving station to determine the downlink C/N or C/N_0 of that link and periodically forward this measured value to the uplinking station on the opposite link. In the event there is excessive link attenuation at the receiving site the uplinking station has the option of increasing the uplink power to the satellite in response (to form a feedback loop) OR to modify the modulation format and/or the degree of coding used on the link. The former method is often not very effective if the overall link is dominated by the uplink C/N already, leaving adaptive MODCOD as the better approach. Clearly, to make this work both the uplink modem and the downlink modem must communicate in order to synchronously adapt to the meteorological link changes as they occur. The standard which has arisen within the broadcast industry to address these problems is an ETSI Standard DVB-RCS-S2. [9] This standard is very powerful and has been adopted and adapted in many parts of the satellite industry. Adaptive MODCOD systems are among the first technologies to exploit Shannon's theory of trading bandwidth for data rate performance, implemented as a series of small changes in both modulation and coding on the link. This has become so effectively implemented that the transmitting and receiving stations will not lose a single bit during a transition between two adjacent steps in the MODCOD table. The theoretical performance of a DVB-S2 modem is given in Table 6, taken from the ETSI-EN-302-307-DVB-S2 standards document. Adaptive MODCOD is also not unique to the commercial GEO satellite market. Several space agencies have developed their own adaptive telemetry standards to cope with rain conditions at mmW. [10] A downlinking remote sensing system could easily use its command uplink to adapt its MODCOD via commands sent by the ground station where the link quality is monitored.

Table 6. DVB-RCS-S2 Adaptive Modem Characteristics

ETSI EN 302307 DVB S2 Theoretical Performance for Target ModCOD															
MODulation	CODing Rate	Es/No	Sym rate	BW (nyq)	C/No	C/N	Spectral Efficiency	Bits/ symbol	Data Rate	Ebi/No	Eb/No	Gross Bit Rate	Info bits	code bits	"overhead"
		dB	Msym/sec	MHz	dBHz	dB	info bit/symbol		Mbps	dB	dB	Mbit/sec	Mbit/sec	Mbit/Sec	
QPSK	1/4	-2.35	41.67	50.00	73.85	-3.14	0.490243	2	20.4268	0.746	-5.360	83.33	20.83	62.50	1.951%
QPSK	1/3	-1.24	41.67	50.00	74.96	-2.03	0.656448	2	27.3520	0.588	-4.250	83.33	27.78	55.56	1.533%
QPSK	2/5	-0.3	41.67	50.00	75.90	-1.09	0.789412	2	32.8922	0.727	-3.310	83.33	33.33	50.00	1.324%
QPSK	1/2	1.00	41.67	50.00	77.20	0.21	0.988858	2	41.2024	1.049	-2.010	83.33	41.67	41.67	1.114%
QPSK	3/5	2.23	41.67	50.00	78.43	1.44	1.188304	2	49.5127	1.481	-0.780	83.33	50.00	33.33	0.975%
QPSK	2/3	3.10	41.67	50.00	79.30	2.31	1.322253	2	55.0939	1.887	0.090	83.33	55.56	27.78	0.831%
QPSK	3/4	4.03	41.67	50.00	80.23	3.24	1.487473	2	61.9780	2.306	1.020	83.33	62.50	20.83	0.835%
QPSK	4/5	4.68	41.67	50.00	80.88	3.89	1.587196	2	66.1332	2.674	1.670	83.33	66.67	16.67	0.800%
QPSK	5/6	5.18	41.67	50.00	81.38	4.39	1.654663	2	68.9443	2.993	2.170	83.33	69.44	13.89	0.720%
8PSK	3/5	5.50	41.67	50.00	81.70	4.71	1.779910	3	74.1629	2.996	0.729	125.00	75.00	50.00	1.116%
QPSK	8/9	6.20	41.67	50.00	82.40	5.41	1.766451	2	73.6021	3.729	3.190	83.33	74.07	9.26	0.637%
QPSK	9/10	6.42	41.67	50.00	82.62	5.63	1.788612	2	74.5255	3.895	3.410	83.33	75.00	8.33	0.633%
8PSK	2/3	6.62	41.67	50.00	82.82	5.83	1.980636	3	82.5265	3.652	1.849	125.00	83.33	41.67	0.968%
8PSK	3/4	7.91	41.67	50.00	84.11	7.12	2.228124	3	92.8385	4.431	3.139	125.00	93.75	31.25	0.972%
16APSK	2/3	8.97	41.67	50.00	85.17	8.18	2.637201	4	109.8834	4.759	2.949	166.67	111.11	55.56	1.10%
8PSK	5/6	9.35	41.67	50.00	85.55	8.56	2.478562	3	103.2734	5.408	4.579	125.00	104.17	20.83	0.858%
16APSK	3/4	10.21	41.67	50.00	86.41	9.42	2.966728	4	123.6137	5.487	4.189	166.67	125.00	41.67	1.11%
8PSK	8/9	10.69	41.67	50.00	86.89	9.90	2.646012	3	110.2505	6.464	5.919	125.00	111.11	13.89	0.77%
8PSK	9/10	10.98	41.67	50.00	87.18	10.19	2.679207	3	111.6336	6.700	6.209	125.00	112.50	12.50	0.77%
16APSK	4/5	11.03	41.67	50.00	87.23	10.24	3.165623	4	131.9010	6.025	5.009	166.67	133.33	33.33	1.07%
16APSK	5/6	11.61	41.67	50.00	87.81	10.82	3.300184	4	137.5077	6.425	5.589	166.67	138.89	27.78	0.99%
32APSK	3/4	12.73	41.67	50.00	88.93	11.94	3.703295	5	154.3040	7.044	5.740	208.33	156.25	52.08	1.25%
16APSK	8/9	12.89	41.67	50.00	89.09	12.10	3.523143	4	146.7976	7.421	6.869	166.67	148.15	18.52	0.91%
16APSK	9/10	13.13	41.67	50.00	89.33	12.34	3.567342	4	148.6393	7.607	7.109	166.67	150.00	16.67	0.91%
32APSK	4/5	13.64	41.67	50.00	89.84	12.85	3.951571	5	164.6488	7.672	6.650	208.33	166.67	41.67	1.21%
32APSK	5/6	14.28	41.67	50.00	90.48	13.49	4.119540	5	171.6475	8.132	7.290	208.33	173.61	34.72	1.13%
32APSK	8/9	15.69	41.67	50.00	91.89	14.90	4.397854	5	183.2439	9.258	8.700	208.33	185.19	23.15	1.05%
32APSK	9/10	16.05	41.67	50.00	92.25	15.26	4.453027	5	185.5428	9.563	9.060	208.33	187.50	20.83	1.04%

In other words, if the measured C/N or C/N₀ at the ground station begins to fade (for whatever reason) the ground station would send a command to the spacecraft to use a more robust form of modulation (increasing from m-ary toward BPSK) or increase the level of coding (more symbols per bit) until the resultant performance recovers or recovers at least to an acceptable level. How effective is this form of sophisticated bit shuffling? The table above shows the 28 MODCOD choices that a modem could select if it supported the entire standard. These range from QPSK with a high coding rate to 32APSK. The latter uses very little coding and is a poor modulation choice from a C/N perspective as it requires 15.26 dB to meet a 10⁻⁶ bit error rate. BUT, it provides a spectral rate performance of 4.45 bits/Hz (i.e., we can achieve a data rate of more than 4 bits/sec in every Hz of bandwidth). Now review the C/N₀ column of Table 6. The C/N₀ of a signal is the same quantity obtained if all of the power from an RF signal were to be placed into a infinitely narrow carrier and the C/N were measured in a 1 Hz bandwidth. So, it is the 1 Hz S/N...that is the easy way to think about it. We notice that over the range of MODCODs the C/N₀ required across all of the steps varies by a total of 18.4 dB. So the range of the signal can decrease, in linear units, by a factor of just about 70 times from top to bottom of the range. The spectral efficiency (or spectral rate) column is then reviewed. Over the full range of signal variation the spectral efficiency has changed from 0.49 bits/Hz to 4.45 bits/Hz or by just a

factor of 9 times (9.5 dB). Now, suppose we were using such a modem on a remote sensing link which produced 100 Mbps under dry, clear-sky conditions at high elevation angles. If a rain cloud were then placed between the satellite and ground station, and the rain attenuated the RF signal (and/or raised the noise) by a total of 18.4 dB, in combination, then the data rate would automatically adapt to a new data rate of 11.0 Mbps until the environment improves. Such an adaptive MODCOD system is very powerful indeed.

The ETSI standard DVB-S2 or the two way version DVB-RCS-S2 is intended for two way communications via satellite transponder. In this case the transmitter MODCOD setting will be adjusted via the command link and a final decision needs to be made regarding the total number of selectable MODCOD settings. Perhaps the 28 individual steps shown in Table 6 are excessive for this application.

In summary, the primary price to be paid for using Ka-Band spectrum (or mmW spectrum in general) is the statistical variations that occur along the link path in terms of excess attenuation and noise generation. The technology to deal with this daemon is adaptive demodulation (MODCOD) which not only allows the system to adjust to instantaneous link conditions but, also assures that the data transfer rate to the ground is also maximized - under any set of real world

conditions. And, further, the system operates within approximately 1 dB of the Shannon limit criterion during times of strong coding and QPSK modulation.

The Directive Antenna Trade

The second substantial price to be paid for using mmW frequencies is the requirement for directive, high gain antennas on even the smallest of satellites. Remember under FACTORS LIMITING THROUGHPUT above, condition 3) stated that in order to increase data rate with increasing frequency we must use directive antennas on both ends of the link. Hence, one is “stuck” with providing a high gain antenna on the spacecraft end of the link as well. In the Pumpkin-MISC example a tiny 100 mm dish antenna was chosen. While that antenna would work very well in principle, it has several critical design and alignment issues. An easier and lower cost approach would be to use a horn antenna. The gain is a little lower and the beamwidth is slightly larger, making the system easier to point. Horn antennas also have higher aperture efficiencies than small dish antennas. For the Antarctic Broadband demonstrator Nanosat, frequencies of approximately 20 GHz were specified for the downlink and 30 GHz for the uplink. Figure 12 shows a drawing of the two horns studied for that mission.

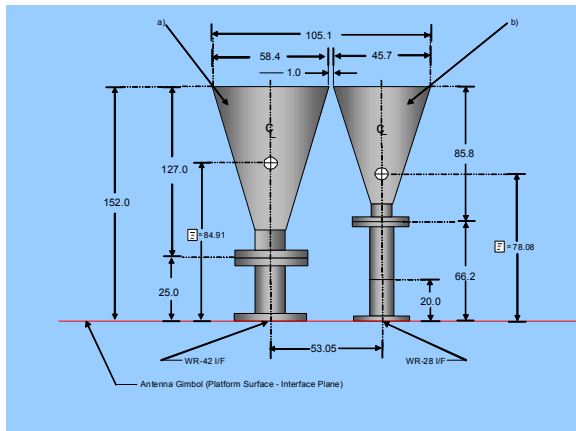

Figure 12. Selected 20 GHz (a) and 30 GHz (b) Horns

The horns include linear-to-circular waveguide polarizers as the use of circular polarization for LEO missions will decrease overall link losses and also simplifies ground station pointing/tracking. The 20 GHz horn and polarizer for the telemetry downlink has an estimated mass of 85 grams and the 30 GHz horn and polarizer for the command uplink has an estimated mass of 78 grams. The antennas each have a gain of about 22.0 dBi and their -3 dB

beamwidth is 10.9°. It is proposed to make use of a horn of slightly higher gain than was used for Antarctic Broadband since the average frequencies are slightly higher. A gain of 24.0 dBiC and a beamwidth of 10.2° will be used for calculations in the remainder of this paper for LEO high speed command and telemetry system applications. Antennas for other frequencies supporting other LEO applications will have very similar performance and characteristics. The two antennas must be mounted on either a single or dual axis positioner. If we allow link losses for spacecraft antenna pointing to be as large as -1dB for this system then an RSS pointing error value of approximately 3.5° can be allowed toward the target ground station. This budgeted error, of course, must include both the platform contribution and the positioner error. So, the pointing requirements fall into the moderate category. Certainly if the target of the payload instrument is at a very specific location on the Earth’s surface, then the accuracy of the antenna articulation should represent no additional burden to the primary referencing sensors. In fact, the largest overhead is likely to be the “book-keeping” associated with the positioner feedback mechanism (where usually, a potentiometer is used and some hysteresis exists).

A decision point is now reached in the design process particularly as the CMD and TLM system may apply to a remote sensing mission. This lies with the means by which the antenna(s) are directed toward the ground station target. As mentioned above, the Nanosat solution we have developed using the GNB platform involves a spacecraft consuming all three directional degrees of freedom to point the antennas at two selectable targets. In the case of Antarctic Broadband the first target is one of two ground stations. For a remote sensing mission where the communications hardware is used for high speed CMD and TLM, the first target is the sensor’s target. In order to point toward the second target (and minimize the complexity of on-board mechanisms) the spacecraft 3rd axis (in this case, Yaw) is used for one component and the single axis antenna positioner (under control of the spacecraft flight computer) for the second component of the vector. For a remote sensing mission this is the vector to the receiving ground station. If the system is used in this manner there is a continuous rotation of the spacecraft about the vector direction toward Target #1 (the observation target) as the ground station moves relative to the spacecraft (viewed here in the spacecraft coordinate frame). This can be seen more clearly in Figure 13. In Figure 13, the body-fixed antenna pair is directed toward and tracks South Pole

Station (SPS), while the actuated antenna pair tracks McMurdo.



Figure 13. Minimized Approach to Two Target Tracking Using Antarctic Broadband Nanosatellite

For some sensor payloads, this may not be a problem as a rotation about yaw may not affect the sensed quantity. However for camera systems and push broom sensor payloads this degree of freedom is not “free.”

That simply means all three spacecraft axes must become involved in pointing the payload, such that the forward motion of the satellite results in an along-track motion of the first pointing vector (the sensor axis). The effect on the TLM antenna system is to require two independent axes of rotation decoupled from the platform. Many satellite systems employ two axis gymbal mechanisms, although this one will nominally require a double rotational waveguide joint integrated into the mechanism. Clearly the more universal approach (and the one which comes out of any serious product trade study) suggests that a two axis mechanism be selected. However, there is yet another question regarding the product itself: Does the spacecraft flight computer calculate the two angles required for directing the antenna toward the ground station or can that be done by an independent

calculation done by the CMD/TLM component operating as an independent subsystem? We leave this issue open for the moment but, it will be resolved in the conclusion of this paper.

MISSIONS ENABLED BY THIS APPROACH

It is perhaps stretching things a bit to suggest that 1U and 2U Cubesat missions could make use of the Ka-Band system that has been currently developed and then adapted for a high speed CMD and TLM subsystem. However, ALL spacecraft larger than a 3U Cubesat, up to and including very large mission spacecraft, might be able to benefit from using mmW communications system using adaptive MODCOD modem technology. Presented here are some exciting examples along with their supporting link budgets (or at least a summary of same).

Remote Sensing High Resolution Imaging Mission

Pumpkin’s MISC mission was an example of a paradigm shift in data rate which enables a very small Nanosat to become commercially viable in at least

some markets. Our example was not fine tuned however, and it may be that for some years to come Micro- or Mini- satellites will become the main-stay for remote sensing missions. A recent study, using this technology has been completed for a European small satellite carrying a push-broom sensing instrument. The performance for that system has been estimated based on meteorological conditions at ground stations in Central Germany. In this case the full ITU-P618-6 rain model has been applied and the performance has been assessed with rain and clouds ON and OFF (clear-sky conditions). We have evaluated both the spacecraft downlink and the CMD uplink. For the uplink we have assumed that simple PSK with no coding is employed with a required

BER of 1.0×10^{-5} . Table 7 summarizes the reconfigured Ka-Band data system's performance over a range of elevation angles and for an assumed orbit altitude of 700 km. The link availability assumed was 99.0%. As the ITU rain model details are not presented here and it is somewhat beyond the scope of this paper to do so, note that for a 10° elevation angle at the ground station the excess path losses at the CMD uplink frequency (34.95 GHz) are -12.54 dB and at the TLM downlink frequency of (26.25 GHz) they are -8.89 dB. Such conditions will prevail or be worse than given here (at this particular location in Europe) 1% of the time and will be less severe than this 99% of the time.

Table 7. Ka-Band High Speed CMD and TLM Link for Remote Sensing Mission

Ground Station Characteristics:

Antennas:	Type:	Size:	Aperture η :	Gain:	Beamwidth:	Polarization:	Motion:
CMD Uplink:	Parabolic Reflector	2.4 m	60%	56.7 dBic	0.25°	RHCP	2-Axis
TLM Downlink:	Parabolic Reflector	2.4 m	60%	54.2 dBic	0.33°	RHCP	2-Axis
Ground Station RF Characteristics:							
CMD TX Power:	1.0 watt						
TLM RX Noise Temp:	360 K						
Ground Station RF Performance:							
CMD Uplink EIRP:	54.2 dBW						
TLM Downlink G/T:	26.6 dB/K						

Spacecraft C&DH System Characteristics:

Antennas:	Type:	Size:	Aperture η :	Gain:	Beamwidth:	Polarization:	Motion:
CMD Uplink:	Horn Antenna	TBD	80%	24.0 dBic	10.2°	RHCP	2-Axis
TLM Downlink:	Horn Antenna	TBD	80%	24.0 dBic	10.2°	RHCP	2-Axis
Spacecraft RF Characteristics:							
TLM TX Power:	1.0 watt						
CMD RX Noise Temp:	495 K						
Spacecraft RF Performance:							
TLM Downlink EIRP:	22.3 dBW						
CMD Uplink G/T:	-4.85 dB/K						
RX IF Filter Bandwidth:	1.0 MHz						
TX IF Filter Bandwidth:	50 MHz						

DEMOD

FIXED BPSK Demod., Data Rate Options: 2.0 kbps, 20kbps, 50 kbps or 100 kbps options
Adaptive Demod: Uses DVB-S2 ETSI Standard MODCOD

Ground Station Location:

Central Germany, Europe	53° N	Lat.	13° E	Long.
-------------------------	-------	------	-------	-------

Command RX Performance:

Telemetry TX Performance:

Full Meteo Link Losses Applied:

Rain + Clouds: **ON**

Command Uplink:			
Elev. \angle :	Demod:	Data Rate:	Margin:
5°	BPSK	50.0 kbps	2.71 dB
10°	BPSK	100.0 kbps	11.67 dB
15°	BPSK	100.0 kbps	16.75 dB
30°	BPSK	100.0 kbps	23.90 dB
60°	BPSK	100.0 kbps	29.38 dB
90°	BPSK	100.0 kbps	30.90 dB

Telemetry Downlink:			
Elev. \angle :	MOD	COD	Achieved Data Rate:
5°	----- Link Doesn't Close -----		
10°	QPSK	1/2	41.2 Mbps
15°	QPSK	9/10	74.53 Mbps
30°	16APSK	5/6	137.51 Mbps
60°	32APSK	9/10	185.54 Mbps
90°	32APSK	9/10	185.54 Mbps

Partial Meteo Link Losses Applied:

Rain + Clouds: **OFF**

Command Uplink:			
Elev. \angle :	Demod:	Data Rate:	Margin:
5°	BPSK	100.0 kbps	14.60 dB
10°	BPSK	100.0 kbps	20.39 dB
15°	BPSK	100.0 kbps	23.15 dB
30°	BPSK	100.0 kbps	27.83 dB
60°	BPSK	100.0 kbps	32.21 dB
90°	BPSK	100.0 kbps	33.42 dB

Telemetry Downlink:			
Elev. \angle :	MOD	COD	Achieved Data Rate:
5°	QPSK	1/2	41.2 Mbps
10°	8PSK	2/3	82.53 Mbps
15°	8PSK	5/6	103.27 Mbps
30°	32APSK	5/6	171.65 Mbps
60°	32APSK	9/10	185.54 Mbps
90°	32APSK	9/10	185.54 Mbps

If attention is paid to the telemetry transmitter performance, as the elevation angle increases one can observe the model of the adaptive modem at work. As the elevation angle increases the excess path loss rapidly decreases and the effective data rate supported goes up. However, the data rate increase is small compared to the dynamic range change in input signal level to the modem caused by worst case rain conditions. This can be more readily observed on the CMD uplink where conventional PSK demodulation is used. If the “margin” column is observed with rain + clouds ON, it can be seen that the signal level changes by more than 30 dB from 5° to 90° elevation angle. On the TLM downlink side of the link table the data rate changes by no more than a factor of 4.5 (or 6.5 dB) over the same range of elevation angles. This clearly shows the vast improvement offered by this technology. One should also not lose track of the fact that both up and downlinks make use of only 1 watt of RF power and the ground station antennas is only 2.4 meters in diameter.

Deep Space Missions

The small satellite community has long wanted to do a deep space mission, however, missions beyond the distance of the moon are daunting for very small satellites because of the link requirements. Link losses at superior conjunction of Mars/Earth are in excess of 282 dB at X-Band and increase to 294 dB at Ka-Band. This is not an easy link to establish by any means. The downlink frequency suggested is approximately 32.3 GHz which is at the top end of the deep space Ka-Band (giving us the highest frequency advantage possible). And it will be necessary to use the JPL Deep Space Network (DSN) system. The DSN is authorized to provide services for both government and commercial missions. A Nanosat mission to Mars can certainly be imagined and even at Ka-Band, this is pushing the link. Some adjustments to the link must be made in order to accommodate the DSN system. [11] Table 8 shows the link for a Nanosat-to-Microsat sized spacecraft using the 34 meter BWG-2 (beam wave guide) system that exists at Goldstone, California. This facility supports the suggested Ka-Band allocation. The spacecraft high gain antenna used is 0.5 meters \varnothing and that would fit on a Nanosat. Pointing accuracy requirements are tight but, manageable. The difficult demand here is the need to use a 4 watt RF mmW transmitter on a Nanosat. A solid state Ka-Band transmitter (a big brother to our Antarctic Broadband version) would likely require about 40 Watts of DC power continuously, while the transmitter is ON. For a deep space mission, the transmitter should be ON as much as possible, so this becomes a system driver

if the RF power is left at this sizing. However, one can find a more comfortable position. The link is shown here at superior conjunction (the farthest possible distance between the two planets). It would be easy enough to drop the RF power back to 1 watt and accept a reduction in data rate from 2400 bps to 600 bps during this portion of the mission. A more typical range between the two planets might be 1.25 AU and at that range, using a 1 watt RF transmitter one can have back the 2400 bps. So, let's stick with that option for this example (1 watt TX power, 32.3 GHz, 0.5 meter dish, 2400 bps normal data rate, 600 bps at SC). It is also necessary to use a fixed demodulation scheme at the DSN. The MODCOD system selected here has been around the DSN since the mid-90s and is well understood by everyone in the deep space business. It is not adaptive. The DSN system can use a 1/6 rate CCSDS Convolutional code with a constraint length, $K=15$ and it is concatenated with a Reed-Solomon 255/223 block code. [11] The resulting performance is such that a 0.8 dB E_b/N_0 link result will achieve a 1×10^{-7} bit error rate. One could probably make small improvements on that performance these days but, it would not be worth the effort to do so. It is also worth noting that a JPL link budget requires 3 dB of margin – *always*. Certainly this is not a fully optimized communications system to take to Mars but, it does prove that Ka-Band and the DSN make a Nanosat or Microsat missions to that planet possible on a stand-alone basis. For those who want to send a 1U Cubesat to Mars, it is suggested that you look for a “big brother” spacecraft to help you relay your data from the vicinity of Mars back to Earth. In summary, this clear-sky link will yield a 69 Mbit (about 7 MByte) return of data per day from a Nanosat at Mars, while meeting all DSN standards requirements.

Niche Market Communications Missions: Satellite-to-Satellite Data Relay

It is observed in Table 5 above that several frequency bands exist for the Intersatellite Service. Systems using this spectrum would NOT be expected to relay data to Earth. This spectrum was chosen by the ITU because it sits very near the water absorption line discussed above. We therefore explore the feasibility of a Nanosat or Microsat TDRSS mission concept using the highest of these frequency bands. Is such a mission feasible? In designing this mission one can finally stop worrying about excess path loss. There will be nothing between the two communicating spacecraft except, good clean vacuum. Wonderful clear-sky conditions will exist always!

Table 8. The Nanosat Link to Mars

Parameter:	Value:	Unit(s):	Comment/Equation:
Spacecraft:			
Transmitter RF Power Output:	4.00	Watts	
Carrier Frequency:	32300.00	MHz	
Wavelength:	0.0093	m	
Antenna Diameter:	0.5	m	
Antenna Aperture Efficiency:	60%		
Antenna Gain:	42.34	dBic	
Antenna -3dB Beamwidth:	1.30	deg.	
Line/Cable Losses:	-1.00	dB	
Switch Losses:	-0.39	dB	
Misc. Transmission Losses:	0.00	dB	
Spacecraft Pointing Error:	0.33	deg.	
Spacecraft Pointing Losses:	-0.70	dB	
Spacecraft EIRP:	46.28	dBW	
Path:			
Polarization Loss:	-1.00	dB	
Range to Spacecraft (Astro. Units)	2.520	AU	AU = 1.5 X 10E+11 meters
Range to Spacecraft (meters)	3.78E+11	m	
Path Loss:	-294.20	dB	
Atmospheric Loss:	-0.10	dB	
Ionospheric Loss:	-0.10	dB	
Rain/Water Vapor Attenuation:	-1.00	dB	
GS Pointing Loss:	-0.10	dB	
Isotropic Signal Level at GS:	-250.22	dBW	
Ground Station (GS):			
GS Antenna Diameter:	34.00	m	
GS Antenna Aperture Efficiency:	74.0%		
GS Antenna Gain:	74.70	dBic	
GS Antenna -3dB Beamwidth:	0.02	deg.	
GS System Noise Temperature:	31.2	K	
GS System Figure of Merit (G/T):	59.76	dB/K	
GS C/No:	38.14	dBHz	
Data Rate:	2.400	bps	
Code Rate:	0.1667	rate	1/2=0.5, 1/3=0.33, 1/6= 0.167, etc.
Symbol Rate:	14397.1	sps	
Matched Filter Eb/No:	4.33	dB	
Demod. Implementation Loss:	0.45	dB	
Required Eb/No	0.80	dB	10E-7 BER w/CCSDS Convolutional
Margin	3.08	dB	Concatenated with Reed-Solomon
Bits Xferred per 8 Hr. DSN Session	66,120,000	bits	

As with TDRSS the spacecraft would be intended to service satellites flying in LEO orbit. The Nano-TDRSS itself will be in GEO orbit. In order to avoid issues related to the atmosphere coming between the Nano-TDRSS and the LEO being tracked the link will not be allowed to go to the maximum range where the LEO sets on the far side of the atmosphere. This is accomplished by limiting the range to the LEO to about 41,700 km. It is assumed the LEO transmits using the same 100 mm dish as the Pumpkin-MISC mission but, it will transmit in a different direction – toward the Nano-TDRSS in GEO orbit. It is assumed the Nano-TDRSS has a “big” 1 meter dish to receive signals from LEO satellites and track them as may be necessary. At GEO the Earth+atmosphere has a diameter of 18° and the half-power beamwidth of a 1 meter dish at 33 GHz (the Intersatellite Service band selected) is 0.64°. So, the TDRSS, indeed, must track the LEO. Only the uplink to TDRSS is presented here. The data is assumed to be demodulated at the satellite with some form of adaptive demodulator, although the dynamic range of signals reaching the TDRSS might not require this feature. There is no significant atmospheric variation for this link as has been discussed. Table 9 gives the link results. Of course, there is a final data relay from the Nano-TDRSS to

the ground required. That is a separate link not discussed here.

Table 9. A Nano-TDRSS Uplink

Ka-Band Satellite to Satellite Link: LEO to Nano-TDRSS

Parameter:	Value:	Unit:
LEO S/C Transmitter Power Output:	30.0	dBm
Transmitter Losses:	-1	dBm
S/C Antenna Gain (10 cm dish; 55% A.E.; 33 GHz):	28.2	dBic
S/C EIRP:	57.2	dBm
Path Loss (33.0 GHz; 41,700 km):	-215.2	dB
Polarization Loss:	-1	dB
Other Misc. Losses (Pointing; Atmosphere):	0.0	dB
Isotropic Signal Level at Nano-TDRSS:	-159.0	dBm
Nano-TDRSS Antenna Gain (1.0 m; 55% A.E.):	48.2	dBic
Nano-TDRSS Effective Noise Temperature:	200	K
Nano-TDRSS G/T:	25.2	dB/K
Nano-TDRSS C/No:	64.8	dBHz
Nano-TDRSS Eb/No (with MOD=8PSK;COD=3/5):	0.73	dB
Channel Bandwidth:	1	MHz
Spectral Efficiency Achieved:	1.77	bits/Hz
Achieved Data Rate:	1.48	Mbps
Link Margin:	0.1	dB

The Pumpkin MISC spacecraft design, with no change in antenna system or RF transmitter can relay to Nano-TDRSS about 1.5 Mbits per second. Nano-TDRSS needs a 1 meter dish to receive the data and a means to retransmit the data to a ground station located conveniently on the Earth, in view of the GEO orbit. It must be acknowledged that it would be unlikely anyone would use a Nanosatellite for a general purpose miniature TDRSS. More likely, such a mission would be accomplished using a Mini-satellite sized Ka-Band system that would be capable of relaying data from multiple LEOs received simultaneously and would require multiple channels and a more sophisticated antenna array, however, the point is, the links work and very small satellites can do the job for a simple, single relay system. Ka-Band makes it happen.

GROUND STATION CONSIDERATIONS

Ka-Band Earth stations offer several advantages compared to lower frequency terminals. The cost of Ka-Band electronics is still relatively high compared to X and S band but, currently the prices are falling rapidly so that the electronics, even the power amplifiers, are no longer a significant cost burden.

The high gain and small beamwidth available from antennas of moderate size considerably lowers the overall Earth station and civil works costs. For example, a 2m Ka-Band antenna has, essentially, the same performance as a 6m X-Band dish. Yet, the 2m antenna can be readily installed and the whole terminal housed within a radome for maximum environmental protection at a much lower cost than the 6m antenna.

The higher gain of the Ka-Band antennas reduces the beamwidth which can lead to stringent demands on pointing accuracy and can be complicated by atmospheric effects such as scintillation. However, the accuracy of motors and position encoders for small systems continues to improve, such that angular resolutions down to 1 milli-degree are now commonplace. Thus, there is no problem in knowing where the antenna is pointing. The difficulty is knowing the location of the satellite in the sky to a high degree of accuracy. Recent advances in compact, low cost monopulse tracking networks for Ka band antennas mean that a tracking option can be added for only a marginal price increase. In this case, once the terminal has acquired the satellite it will stay locked to it, typically to an accuracy of about 1/10 of the antenna's beamwidth. So a 2m antenna with a beamwidth of about 0.5deg at 21GHz can readily point to an accuracy of 0.05deg which will result in virtually no pointing loss (an exceptional outcome not possible with "open-loop" tracking methods). Satellite acquisition and lock can be achieved quite quickly even if atmospheric effects cause the signal from the satellite to appear to be offset from the satellite's true direction.

Thus a network of small, low cost Ka-Band Earth stations could complement the array of low cost Nanosats giving a high reliability, very high bandwidth network with mesh-like redundancy.

Since Ka-Band terminals are small, readily enclosed within radomes and able to acquire and track the satellite, this opens up a new opportunity for the satellite/ground station network.

Ka-Band terminals can now be configured for portable and mobile applications. The terminals can and are being mounted on cars, trucks and ships and have been demonstrated to work at data rates up to 8Mbps over a GEO link, (with 26Mbps unit under development) using antennas as small as 600mm. Even higher data rates can be readily achieved by increasing the antenna diameter. Even 2m antennas have been shown to still be practical for such mobile applications.

EQUIPMENT TO BE OFFERED BY ANTARCTIC BROADBAND

The promise of installing Ka-Band communications equipment on-board very small but, now capable spacecraft is great. It is not overstepping boundaries to refer to these enabling features as providing a paradigm shift in data throughput for small satellites. Ka-Band technology, as has been demonstrated here, can be used in a variety of ways. It has also been

shown that there are a few fundamental trades associated with the spacecraft's tracking of the receiving ground station(s). The Ka-Band user must choose between a one-axis antenna positioner, whereby the satellite must yaw about one axis in order to point toward the ground station or a two-axis antenna positioner whereby the satellite uses all three degrees of rotational freedom to point the primary sensor and either the AOCS system or an independent controller must provide the necessary commanding of both axes of the positioner. Antarctic Broadband and/or its partners plan to make suitable equipment available to the small satellite market. Tables 10 and 11 summarize the specific equipment items that will be made available depending upon the AOCS mode chosen. It is realized that some satellite designers may wish to drive the antenna positioner using their own AOCS computer (presumably the same one used to point the primary instrument). Hence, the mission designer can choose between controlling the positioner using existing platform resources or make use of the offered AOCS system. It is also realized that the single axis antenna control approach is essentially the Demonstration Antarctic Broadband mission with the first target antenna pair replaced by a remote sensing instrument boresighted toward Target #1. Hence, another solution that can be offered to clients is that they simply purchase the GNB satellite bus from UTIAS/SFL. At this time, as the satellite design is at CDR level of maturity, much of the NRE would be avoided and only the modifications necessary to support the instrument are required to be carried out. In fact, for most applications which would allow a single axis positioner to be used, this would be a preferred solution by all concerned.

Table 10. Ka-Band TLM/CMD Components (Single Axis Antenna Control System)

<i>System Component:</i>	<i>Comment:</i>
Telemetry Transmitter	Appropriate Band; 1 Watt
Command Receiver	(Optional); > 100 kbps
Transmit Horn Antenna	24 dBiC gain
Receive Horn Antenna	24 dBiC gain (optional)
1-Axis Antenna Positoner	Can support 2 antennas

AOCS Flight Computer*	Controls P and R to point sensor and Y and positioner \angle to support Ka-band TX and RX
AOCS Flight Software*	Supports 2 Target Solution
Ka-Band Ground Station	0.5 to 2.5 m; monopulse or program track; adaptive MODCOD

* AOCS Components are optional if a client already has a flight computer system capable of performing a two target solution as discussed above.

Table 11. Ka-Band TLM/CMD Components (Two-Axis Antenna Control System)

<i>System Component:</i>	<i>Comment:</i>
Telemetry Transmitter	Appropriate Band; 1 Watt
Command Receiver	(Optional); > 100 kbps
Transmit Horn Antenna	24 dBiC gain
Receive Horn Antenna	24 dBiC gain (optional)
2-Axis Antenna Positoner	Can support 2 antennas
AOCS Flight Computer*	Controls P,R and Y to point sensor at target and controls 2 positioner \angle s to support Ka-band TX and RX
AOCS Flight Software*	Supports 2 Target Solution
Ka-Band Ground Station	0.5 to 2.5 m; monopulse or program track; adaptive MODCOD

* AOCS Components are optional if client already has a flight computer system capable of controlling a two-axis positioner and directing it to the ground station target as discussed above.

In the case where a two axis antenna positioner is selected the NRE cost for Antarctic Broadband to adapt to specific mission requirements must be considered by the client. This option may favor a solution whereby the client develops the hardware/software to control the 2-axis positioner.

SUMMARY

The advantages of using higher frequencies for very small satellites have been aptly demonstrated here. Even a 3U Cubesat LEO mission can deliver more than 100 Mbps when fitted with an appropriate Ka-Band system (which requires about a 1U volume). The approach may be adaptable downward to even smaller systems. The system can be used for a variety of important missions including remote sensing, deep space science and satellite-to-satellite cross links. The cost of the systems which make this possible is modest, in comparison to any other known equivalent solution. Ground station installations, in fact, require much smaller aperture antennas than their equivalent S-Band or X-Band counterparts, however, ground antenna pointing accuracy requirements will likely *increase* for most mission concepts. It has been demonstrated that adaptive MODCOD systems offer significant mission advantages in almost all complex mission cases and that such means are essential in dealing with the variability of link conditions when using mmW communications systems.

ACKNOWLEDGEMENTS

The authors wish to thank Pumpkin, Inc. for allowing tables and figures to be used from their excellent USU/AIAA Small Satellite paper from 2008 demonstrating that even a Cubesat is capable of a significant Earth-oriented optical mission. We also wish to thank SSTL for allowing us to use information obtained from their NigeriaSat-2 mission so that it is possible to show where the state-of-the-art is right now in small satellite remote sensing.

We also want to thank the Australian Commonwealth Department of Innovation, Industry, Science and Research (DIISR) for their strong support and their funding of the Antarctic Broadband programs as this outcome clearly stems from that research initiative.

REFERENCES

1. <http://ejournal.com/2011/skybox-imaging-plans-high-resolution-constellation> and <http://www.skyboximaging.com/>

2. Clark, Keith and Maynard, Kevin, *"I Can See You!"- How Satellite Imagery Dictates the Need for Speed*, ARMMS RF & Microwave Society Conference, 25 Nov. 2008, Corby, Northamptonshire, UK.
3. Sri Surmantlyo, Josaphat T, *Development of Circularly Polarized Synthetic Aperture Radar (CP-SAR) Onboard Small Satellites*, Paper IP5-0334, Proceedings of PIERS, Marrakesh, Morocco, 20 Mar 2011.
4. Kalman, Andrew and Reif, Adam, *MISC – A Novel Approach to Low-Cost Imaging Satellites*, Paper SSC08-X-03, 22nd Annual AIAA/USU Conference on Small Satellites, August 2008.
5. King, Jan A., *Can Small Do What Big Does – Only Better (An Update)*, Paper SSC11-VII-01, 25th Annual AIAA/USU Conference on Small Satellites, August 2011.
6. Bonin, Grant et al., *The Antarctic Broadband Demonstration Satellite: Fast Internet for the Bottom of the earth*, Paper SSC11-IV-08, 25th Annual AIAA/USU Conference on Small Satellites, August 2011.
7. Ippolito, Lewis J., *Radiowave Propagation in Satellite Communications*, Van Nostrand Reinhold Company, Inc., 1986, Chapters 4 and 5.
8. Crane, R.K., *Prediction of Attenuation by Rain*, IEEE Trans. On Communications, Vol. COM-28, pp. 1717-1733, Sept. 1980.
9. ETSI Document: Digital Video Broadcasting (DVB); *Second generation framing structure, channel coding and modulation systems for Broadcasting, Interactive Services, News Gathering and other broadband satellite applications*, ETSI EN 302 307 DVBS2, Ver. 1.2.1, 2008-9.
10. Consultative Committee for Space Data Systems Document: CCSDS-131.0-R, *Flexible Advanced Coding and Modulation Scheme for High Rate Telemetry Applications*, Draft Red Book, 1 Nov 2009.
11. Martin, Warren L., *AMMOS and DSN Support of Earth Orbiting and Deep Space Missions*, NASA JPL Document: D-13973, 2nd Edition, Telecommunications and Mission Operations Directorate (TMOD), Future Missions Planning Office, 3 October, 1996, pp. 45, 100.